



Woodworking Education Center (WEC)

Shop Usage and Safety Training Guide

Version 7

November 26, 2024



Table of Contents

Overview	4
Objective	4
Scope	5
Guide.....	5
Responsibilities	5
WEC Manager	5
WEC Supervisors	5
Guild Members	6
Training Requirements.....	6
General WEC Shop Safety Guidelines	7
General Power Tool Safety Guidelines	13
WEC Dust Collection Systems	14
URL: https://www.youtube.com/watch?v=B06Wgrrqb3Y&t=45s	14
Band Saw	15
Table Saw	21
Dado Saw	26
Power Miter Saw.....	28
Jointer	31
Thickness Planer	36
Drill Press	39
Oscillating Spindle/Disk/Belt Sanders	43
Drum Sander	46
Handheld Router.....	50
Router Table	54
Bench Grinder and Tool Sharpening	58
Lathe	62
Scroll Saw.....	72
Portable Power Tools and Hand Tools.....	75



Track Saw 78

Hollow Chisel Mortiser 81

Domino Mortise and Tenon Jointer 84

APPENDIX..... 88

Revision History	Change	Revised By and Date
Version 1	Original version compiled and edited by George Van Kirk	George Van Kirk – 11/15/23
Version 2	Proofed and edited by Julie Erwin	Julie Erwin – 1/21/24
Version 3	Includes all edits and comments by Julie Erwin and Randy Hjetland Operations and Hazards tables to all equipment by G. Van Kirk	George Van Kirk – 2/12/24
Version 4	Includes final edits from Randy Hjetland, George Van Kirk	George Van Kirk – 2/15/24
Version 5	Cumulative edits from review of Version 4	George Van Kirk – 3/14/24
Version 6	Cumulative edits from review of Version 5, addition of QR codes linking to machine short instructional videos	George Van Kirk – 8/12/24
Version 6.1	Added URL video links to all tool articles	George Van Kirk – 6/20/24
Version 7	Added Training Requirements tables for each machine type	George Van Kirk – 11/26/24

Note To Supervisors – suggested process for use of this Training Guide

1. Ask the trainee(s) what projects they have in mind and tailor the machine training to their project idea(s).
2. Train only 1-2 machines per training session appropriate to their projects.
3. Have the trainee(s) read AWG-1 (appendix) and the General Shop Safety Guidelines and watch the video on shop safety. **Emphasize that members are responsible for their own safety (AWG-1)** and go over their responsibilities.
4. Each machine type has a table of OPERATIONS and HAZARDS. Emphasize this table and present the material procedures as mitigators for the HAZARDS.
5. Have the trainee(s) read through a particular machine article, watch the video(s) and then demonstrate each training requirement.
6. Training requirements to be demonstrated are summarized at the end of each machine article. Demo each machine training requirement, noting where the trainee(s) have difficulties and note in the “Remarks” section of the signoff sheet.



Overview

An important part of everyone's experience in woodworking is understanding the importance of and following safe practices and procedures to prevent injuries to YOURSELF and OTHERS at the Woodworking Education Center (WEC), hereafter referred to as the WEC.

All Alabama Woodworkers Guild (hereafter referred to as the "Guild") members must participate in safety and WEC usage training and demonstrate proficiency on each piece of equipment in the woodshop before working independently on said equipment. Member training and qualifications are provided by the WEC Supervisor and documented on the Guild training form.

Experience in the woodshop does not automatically guarantee safety awareness. Experienced woodworkers may suffer injury due to over-confidence in ability rather than adhering to safety guidelines.

All Guild members must abide by the shop rules and restrictions (in accordance with the AWG-1 policy, *Use of the Woodworking Education Center*).

NEVER be afraid to ask a supervisor for help.

NEVER use a machine without having a clear understanding of its operation, intended use, and machine hazards.

Objective

The objective of this guide is to foster a safety culture at the WEC and to establish safe work practices for Guild members using machinery and equipment in the woodshop. The target audience for this guide are the WEC Supervisors and the Guild membership. The guide contains safety guidelines and training requirements designed to minimize the risk of injury. The plan is intended to ensure:

- Guild members are provided training and information on how to protect themselves from shop and machine hazards,
- Recommended maintenance is conducted, and standard operating procedures are in place for machinery and equipment use,
- Only persons trained and knowledgeable in the use of WEC equipment use that equipment, and



- All work is performed in accordance with referenced safety requirements.

Scope

As a reference, the training guide uses the OSHA Woodworking Machinery Standards, 29 CFR 1910.213, and A Guide for Protecting Workers from Woodworking Hazards, OSHA 3157 dated 1999.

Guide

The Shop Usage and Safety Training Guide establishes the minimum requirements necessary to allow the safe use of equipment located at the WEC. The WEC Manager will ensure that a copy of the WEC access policy, hours of operation and shop safety rules and procedures is posted.

Responsibilities

WEC Manager

- The WEC Manager shall establish and administer safety rules and operational procedures for the WEC. Questions concerning the training guide exceptions or clarification on WEC operation must be directed to the WEC Manager for review and comment. If deemed appropriate, training guide exceptions/clarifications will be presented to WEC Lead Supervisor and WEC Shop Supervisors for review and comment before initiating at the shop level.
- The WEC Manager will perform other actions as necessary (e.g., safety audits) for the safe, efficient, and orderly operation of the WEC.
- The WEC Manager has final authority over all safety issues and may halt any operation or procedure deemed unsafe.

WEC Supervisors

- The Lead Supervisor and the duty Supervisors shall enforce safety rules and procedures in effect and indoctrinate Guild Members as to WEC rules and procedures.
- Supervisors on duty shall maintain WEC facilities and equipment including all safety and health equipment during their shift.
- Supervisors on duty have the authority to halt unsafe operations at any time and to restrict access to the WEC by any member violating the stipulations of this plan.
- Safety gear is in the cabinet marked Safety Gear, nearest to the kitchen door.



- Supervisor should maintain first aid, CPR, and AED training. Any injury as well as any unsafe conditions, actions or near-miss incidents must be reported to and documented in detail by the supervisor on duty. **All incidents and near misses provide learning opportunities for all associated with the WEC.**

Guild Members

- Any Guild member using the WEC is expected to be aware of and comply with all shop rules and regulations as set forth in AWG-1, *Use of the Woodworking Education Center*. **Members are responsible for their own safety.**
- Guild members must receive required training, demonstrate proficiency, and be signed off by an approved WEC Supervisor prior to working with any power tools, woodworking equipment or other shop related equipment.
- All Guild members must properly use any required personal protective equipment (PPE) while working in the woodshop.
- Follow all safety guidelines as presented in this guide and as posted in the WEC.
- Consumption of alcoholic beverages on WEC premises or operating any WEC equipment while impaired by medication, drugs, or alcohol is strictly prohibited.

Training Requirements

Training in safe and efficient usage of WEC equipment must be completed and documented by a WEC supervisor before a Guild member is allowed to work in the WEC.

Required training includes but is not limited to the following:

- Typical woodworking operational capabilities of each machine.
- Information on the hazards associated with a particular machine or piece of equipment, including a working knowledge of how a piece of machinery functions so the user can anticipate risks and hazards while working.
- The safety precautions that must be followed when working with a particular machine or piece of equipment, including the purpose and function of any guards that are in place.
- The types and limitations of any personal protective equipment (PPE) required in the shop.



- Procedures to be followed in the event of machine malfunctions or when damage to the equipment occurs.
- Procedures to be followed in the event of an emergency.
- Cleaning procedures per machine.
- Use of approved materials when using WEC tools. (projects using pressure treated lumber or lumber/materials with metal hardware are not allowed in the WEC; **ANY** wood must be checked for metal such as nails or screws; no use of painted boards unless paint has been removed).

All training must be documented in writing with the records maintained in the WEC. Remember that members are responsible for their own safety.

General WEC Shop Safety Guidelines

Watch a short video at the QR code or URL on WEC shop safety guidelines.



URL: <https://www.youtube.com/watch?v=8JX3xEbyJCK>

EYE PROTECTION AND PERSONAL PROTECTIVE EQUIPMENT (PPE)

Use of Appropriate PPE is the responsibility of the Guild member.

Always wear appropriate eye protection. Wear safety glasses or a face shield when doing any operation that may endanger your eyes. Be sure you have enough good light to see what you are doing without straining your eyes. **Always keep your eyes on the cutting action.** Note additional PPE recommendations for each machine type.

HAIR & CLOTHING

Dress properly for your work. Secure loose coats and jackets or remove loose clothing that can potentially get caught in power tools or other shop equipment. It is advisable to wear a shop apron that is snugly tied. Wear closed toe shoes. Keep long, loose hair restrained and securely tied back to prevent machine and tool entanglement.



HORSEPLAY IN THE SHOP

Horseplay in the shop will not be tolerated.

CONSIDERATION OF OTHERS

Be thoughtful and helpful toward other Guild members in the WEC. Do not distract other members while they are working and especially when a member is operating machinery. Be sure the work you are doing does not endanger someone else.

OPERATIONS WHEN ILL OR TIRED

Do not operate machinery or use tools if you feel sick, tired, are on medication, or intoxicated.

BEFORE WORKING IN THE SHOP

Before beginning a work session, let the supervisor know what you plan to do. All youth members must secure approval for their projects from their mentor. Any guild member should seek advice from the supervisor or mentor if unsure about a particular project or project approach.

BROKEN TOOLS

Report broken tools or strange machine behavior to the supervisor.

MACHINE WORKING SPEED

Do not “rush and tear” through your work. A good woodworker knows that a steady, unhurried pace is safest and produces the best work. Always allow the machinery to come to full speed before engaging any materials with a tool. Never start a piece of machinery with materials engaged. Do not force material into a machine.

TOOL SELECTION

Select the proper size and type of tool for your work. **An experienced woodworker never uses a tool unless it is sharp and in good condition.** Inform the supervisor if tools are found to be broken, dull, have loose handles, or need adjustments.



CARRYING TOOLS

Keep sharp-edged and pointed tools turned down. Do not swing or raise your arms over your head while carrying tools. Carry only a few tools at one time unless they are in a special holder. Do not carry sharp tools in the pocket of your clothes.

CLAMPING STOCK

Whenever possible, mount the work piece in a vise, clamp, or special holder. This is especially important when using chisels, gouges, or portable electric tools.

BENCH ORGANIZATION

Keep project materials carefully organized on the bench with tools located near the center. Do not pile tools on top of each other. Never allow edged or pointed tools to extend out over the edge of the bench. Close the vise when not in use and see that the handle is turned down. Keep drawers and cabinet doors closed.

CLEANLINESS

Keep your hands clean and free of oil or grease. You will do better and safer work, and the tools and your project will stay in good condition. Keep machines clean. Remove all tools, wood, and unnecessary materials. Never use a tool bed as a worktable. Objects left on the machine can vibrate into revolving cutters. They can then be thrown from the machine with great force. Never clean a machine while it is running. Always use the dust collection system if available. Maintain good housekeeping by regularly cleaning work areas.

CONFIDENCE

As you learn to operate a machine, you will gain confidence. Do not become too confident. Overconfidence leads to carelessness, and carelessness causes accidents. This does not mean you should be afraid of machinery; however, a safe attitude is one of respect for what machines can do.

ELECTRICITY

- Before plugging in a machine, make sure the switch is in the “off” position. (Unexpected startups must be avoided.)
- If you use an extension cord, use the correct wire size. This is determined by the length of cord and size of motor. Using a wire size that is too small will cause the tool to overheat. Consult the supervisor if you are unsure about a cord.



- Per fire code, an extension cord must be “put away” and either coiled or retracted into housing.
- Keep all power cords away from blades and cutters while you work. Make sure the power tool is grounded. One with a double-insulated case need not be grounded. If you are unsure about this, check with the supervisor.
- If anything unusual happens turn off the machine immediately. If the machine does not sound right, turn it off immediately. As soon as it stops completely, alert the supervisor to the machine’s condition. If you need to switch off a tool during an operation where the tool is still in contact with a piece of material, never let go of the material; hold it still until the tool has come to a complete stop.

FIRE PROTECTION

- Familiarize yourself with the location of all fire alarms/pull stations and fire extinguishers.
- Under normal operating conditions, applying finishes to wood projects in the shop is not allowed.
- Close cans of solvent and thinners immediately after use.
- Use flammable liquids in very small quantities. Be sure the container is labeled. Flammable liquids are stored in the red flammable liquids locker (by the library).
- Consult workers near you to determine whether any potential crossover hazards might be present.
- Dispose of oily rags and other combustible materials immediately.

INJURIES

Report all injuries, regardless of severity, to the WEC supervisor on duty. Following the initial notification, supervisors should complete a [SUPERVISORS' ACCIDENT INVESTIGATION REPORT](#) for submittal to the WEC Manager.

LIFTING

Protect your back muscles when lifting heavy or awkward sized objects. Have someone help you. Lift with your arm and leg muscles. Secure help with long boards, even if they are not heavy.

MATERIAL AND PROJECT STORAGE

No personal projects will be stored in the WEC overnight.



ODORS

Be alert for any odors or smoke that might indicate overheating of the machine or stock.

SAFETY GUARDS

Ensure all safety guards are in place. Never remove a safety guard without supervisor permission. If you have questions, ask the supervisor to check each setup before you begin working.

STANCE

Stand in a comfortable, balanced position when working with power tools. Both feet should be firmly on the floor. Try to be as relaxed and comfortable: if you are unsure about your comfort with the equipment, consult the supervisor.

SUPERVISOR ON DUTY

When the shop is open for member use, a supervisor is always on duty.

UNSAFE PRACTICES OR CONDITIONS

Notify the supervisor of any unsafe practices or conditions you see in the shop.

USING TOOLS

Hold a tool in the correct position while using. Most edged tools should be held in both hands with the cutting motion away from yourself and others.

- Be careful when using your hand or fingers as a guide to start a cut. Test the sharpness of a tool with a strip of paper or a scrap of wood.
- Always keep your hands a safe distance from cutters and blades. Minimum distance recommendations are found in each tool description.

VISITORS

The Guild welcomes visitors. Visitors will be issued a temporary badge for their length of stay. Visitors may not operate WEC equipment but may assist a Guild member in project tasks such as moving, holding, or stabilizing wood.

WATER

Never work in or around water with power tools. Water increases the chances of severe electrical shock.



WOOD

Defects in the wood can be dangerous. Check the stock carefully for knots, splits, and other defects. Check **ALL** wood for metal using the metal detectors provided by the Guild. Clean dirty boards with a wire brush before using any machine or tool.



General Power Tool Safety Guidelines

- Think through an operation before performing it: what you are going to do, what the machine can do, where your hands will move, where you stand, etc. **Do not perform an operation if you are unsure or uncomfortable about doing it.**
- Check wood for metal with a metal WEC metal detector and remove dirt and dust with wire brush before cutting or milling on the wood with any WEC power tool.
- Machines should not be used for operations outside of designed specifications, e.g., on small pieces of stock.
- Maintain the MARGIN OF SAFETY specified for the machine. This is the minimum distance of your hands to the point of tool cutting action while in operation.
- Do not allow your attention to be distracted while operating a machine. Also, be certain you do not distract the attention of other machine operators.
- Always be sure you are trained and signed off to operate a WEC machine (check with the supervisor on duty if you are unsure whether you are approved for use of a particular machine, or unsure about machine operation).
- When you are operating a machine, you are the only one to control it. Start and stop the machine yourself. If someone is helping you, be sure they understand what they are expected to do and how to do it.
- Make all necessary adjustments before turning on a machine. Some adjustments will require the supervisor's approval.
- Never remove or adjust a safety guard without the supervisor's permission.
- Use approved push sticks, push blocks, feather boards, and other safety devices. Some operations may require the use of a special jig or fixture.
- Keep machine tables and working surfaces clear of tools, stock, and project materials. Also keep the floor free of scraps and excessive litter and clutter.
- Allow the machine to reach its full operating speed before starting to feed the work.
- Never leave a machine running while unattended (e.g., don't leave the machine running while finding a push stick or some other accessory).
- Feed the work carefully and only as fast as the machine will easily cut.
- If a machine is dull, out of adjustment, or not working properly, turn the power off immediately and inform the supervisor.



- When you have completed an operation on a machine, turn the power off. Wait until it stops before leaving the machine or setting up another cut. Clean the machine and area around machine before moving on to next operation.
- Stay clear of machines being operated by other members. See that other members are “out of the way” when you are operating a machine.
- Do not “crowd around” or wait in line to use a machine. Ask the present operator to inform you at your workstation when finished. Common standards of courtesy may slow you down, but they will make the shop a safer and more pleasant place to work.

WEC Dust Collection Systems

Woodworking projects generate a lot of sawdust which is a constant cleanup chore and potentially harmful to respiratory health. The WEC has a dedicated dust collection system that is always on whenever machines are running that captures and collects



much of the wood and dust particles from the larger machines in the shop, saving many hours of cleanup and ensuring that members are not exposed to unnecessary airborne respiratory hazards. Additionally, many smaller tools have dust removal capabilities through hose connections and shop vacs.

Many of the larger shop machines have a device in the dust collection plumbing called a “blast gate”. Blast gates open and close automatically when a machine is powered up to let you control a dust collection system’s vacuum pressure in order to achieve maximum suction at a desired tool station. Our blast gates are programmed to remain on for 50 seconds after the tool is powered off to remove remaining dust and wood chips.

It is critically important that Guild members do not attempt to modify or manually open blast gates. Contact the supervisor should a problem arise with machine dust collection.

Watch a short video at the QR code or URL on blast gate operations.



URL: <https://www.youtube.com/watch?v=B06Wgrrqb3Y&t=45s>



Band Saw

The bandsaw is a power saw with a long, sharp continuous blade consisting of a band of toothed metal stretched between two large wheels. Advantages include uniform cutting action across the workpiece and the ability to cut irregular or curved shapes like a jigsaw. The blades come in a variety of sizes and tooth pitches (teeth per inch, or TPI) depending on the woodworking operation required. Narrower blades are for cutting tighter curves, wider blades are for the larger resaw operations.



WEC Machine Nomenclature

Laguna 14 -Twelve

Rikon 14"

Laguna 18bx

BABS 36" bandsaw

Watch a short video at the
QR code or URL on
Bandsaw operations.



URL: <https://www.youtube.com/watch?v=B7T71I-YQZk>



Operations	Hazards
Rip cutting	Contact with blade
Cross cutting	Nip points between blade and wheels
Curve cutting	Rotating parts
Resawing	Flying chips

GENERAL SAFETY GUIDELINES – see General Power Tool Safety Guidelines

MACHINE-SPECIFIC GUIDELINES

GUIDELINES BEFORE MACHINE OPERATION

- **Report all problems to the supervisor.**
- Make sure the blade has teeth pointed down and in front of guide.
- Tension the blade with the Quick Release Lever (Laguna and Rikon bandsaws)
- Check and make sure the blade tension is set for the size of blade.
- Check blade alignment tracking window - blade should be at the center of wheel.
- Check upper and lower guides for correct adjustment.
- On the Rikon bandsaw, check the bearings to make sure they rotate freely.
- On the Laguna bandsaw, open the lower wheel compartment door and check to see if dust blanking block is in place. Close the door and ensure the lower guide protective panel is up and locked.
- Open the blast gate on the dust system.
- Adjust upper guide support arm to about a 1/4" above workpiece.

GUIDELINES DURING MACHING OPERATION

- Keep your fingers at least 3 inches from the blade.
- Always practice on scrap wood before cutting on the workpiece.
- Make relief cuts prior to long or tight corners.
- If you need to back out of a cut, shut the machine off, wait until blade stops, and then back out of the cut.
- If the work is too long for you to handle, get help holding the stock.



- If the blade breaks. Shut off the machine and stand clear until everything stops.
- Before removing cutoffs or blowing off sawdust, shut off the machine and let the blade stop.
- Never push an object into the blade to make the blade stop faster.
- Note: dust collection blast gate will remain open for 50 sec after machine is powered down.

GUIDELINES FOR CLEANUP

- Shut off the machine before cleanup operations.
- Remove cutoffs and blow out the upper and lower wheel compartments.
- Blow out lower and upper guides and check for cutoffs. Clean off any built-up residue on the lower guide.
- Blow off the outer part on machine and tabletop.
- Unlock and lower support arm.
- De-tension blade
- Sweep up.

PROCEDURE FOR MACHINE SET UP AND ADJUSTMENT

- Always shut off the machine before making adjustments.
- Raise guide arm and lock.
- Tension the blade.
- Remove throat plate.
- Blow out upper and lower guide area and clean residue off lower guide.
- Lower bottom guide protective panel (Laguna).
- Loosen top and bottom guides.
- Check tracking of blade in tracking window.
- Adjust top rear guide.
- Adjust top side guides.
- Adjust bottom rear guide.
- Adjust bottom side guides.
- Test spin by hand.
- Put throat plate back in.
- Close wheel compartment doors.

Watch a short video at QR code or URL on adjusting blade guides

<https://www.youtube.com/watch?v=d0EhyANcYWY>





- Raise bottom guide protective panel and lock in place (Laguna).
- Plug in.
- Turn on for test run.
- Shut off machine and allow to come to complete stop.
- Unlock and lower arm.
- De-tension blade with the Quick Release Handle.

PROCEDURE FOR CHANGING BLADES

- Unplug the machine from power.
- De-tension the blade with the Quick Release Handle.
- Raise guide arm and lock.
- Open upper wheel compartment door and the blade guide door.
- Open doors on the Rikon. On Laguna bandsaw, lower bottom guide protective panel and then open the lower wheel compartment door.
- Remove throat plate.
- Remove table split clamp.
- Blow out sawdust from the upper and lower guides.
- Remove plastic blanking plate (On Laguna bandsaw only).

PROCEDURE FOR REMOVING THE BLADE

- Slide the blade off the wheels and out through the slot in vertical column.
- Turn the blade sideways and move teeth first out of table split.

PROCEDURE FOR INSTALLING BLADE

- Slide blade into table slit back first.
- Fit blade into slit on column.
- Hang on the upper wheel.
- Position blade on lower wheel.
- Tension the blade with the Quick Release Handle.
- Rotate the blade by hand.
- Check to see if the blade is tracking in the center of wheel. Correct if necessary.
- Set tension on blade with the Quick Release Handle.

Watch a short video at QR code or URL on blade installation.

<https://www.youtube.com/watch?v=JZNB4FZTetQ>





- Adjust guides to manufacturer's specification (located on wall by each bandsaw).
- Close upper blade guide door.
- Replace plastic blanking plate for Laguna bandsaw.
- Close doors. On Laguna raise bottom panel and lock.
- Install throat plate.
- Install table split clamp.
- Lower guide arm to working position and clamp.

ADVANCED BANDSAW OPERATIONS - See supervisor for training sources.

- Pattern sawing.
- Narrow rip cutting and setup.
- Circle work and using circle jig.
- Bevel cut for turning spindle stock.
- Tilting table operations.
- Bowl blank cut out.
- Using the 36" bandsaw (BABS).
- Using the 18" bandsaw for resawing.

CLEAN UP

- Remove cutoffs and blow out upper- and lower-wheel compartments.
- Blow out lower guides and check for cutoffs. Clean off any built-up residue on lower guides.
- Blow off the outer part on machine and tabletop.
- Clean the blanking plate (Laguna 12") of all dirt.
- Unlock and lower arm.
- De-tension the blade with the Quick Release Handle.
- Sweep up.



SUMMARY OF BANDSAW TRAINING REQUIREMENTS

#	Training Requirement	Complete
1	Identify the location of all bandsaw machine controls	
2	Make a relief cut	
3	Proper method to back out of a cut	
4	Make a wavy cut	
5	Change a blade	
6	Set guides to manual specifications	
7	Coil and uncoil a bandsaw blade	
8	Discuss clean up procedures	



Table Saw

Table saws are designed to rip cut, crosscut, bevel cut, and miter cut with precision. The general types of table saws are compact, bench top, jobsite, contractor, hybrid, cabinet, and sliding table saws. The WEC table saws are the cabinet type, which are heavy cast iron and steel, to minimize vibration and increase accuracy.

- The main parts of a table saw are:
- Base cabinet:
 - Motor and belts.
 - Arbor and saw.
 - Elevation and tilting mechanisms.
 - Power cut off switch.
 - On/off switch.
- Tabletop:
 - Fence
 - Miter gauge.
 - A blade insert in the table where the saw blade comes through.
- Saw blades: (Show types of blades and storage till.)
 - Rip—for cutting with the grain, 32 teeth or below
 - Crosscut—for cutting across the grain. 60-plus teeth
 - Combination—for light duty rip and crosscuts. 40-50 teeth
 - Plywood—designed to prevent tear out of veneer of the plywood



Watch a short video at the QR code or URL on table saw operations.



URL: <https://www.youtube.com/watch?v=91v0Yg1L4ok>



Table Saw Operations	Table Saw Hazards
Rip sawing	Amputation
Cross cutting	Kickback
Beveling	Flying objects
Mitering	Dust inhalation

Examples of Bevel and Miter Cuts

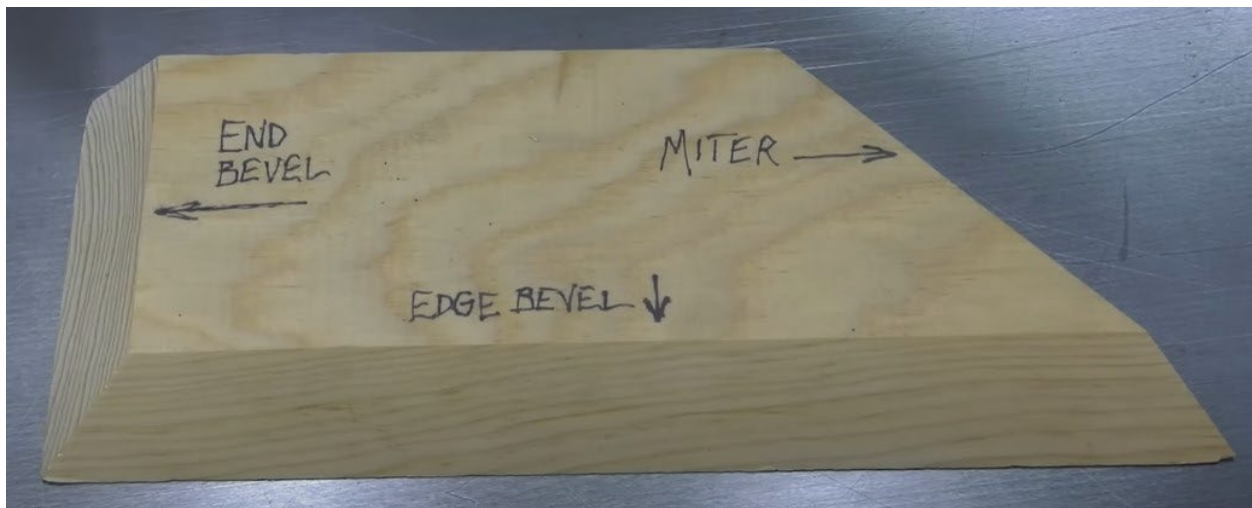

SAWSTOP SAFETY SYSTEM

- This is a sensing system that senses when flesh is in contact with the saw blade and then lowers and stops the blade. This system reduces the potential for serious injury to an operator, coming in contact with the blade but sacrifices the blade brake and sometimes the blade.
- The safety system of the saw initializes on saw power up and then puts the saw in Standby Mode. The saw is ready to run when the green light comes on steady (near the power switch). If a red indicator comes on, do not attempt to start the saw, and contact the supervisor.
- No wet wood, newly glued wood, or treated wood can be cut on the Sawstop.
Glued boards must dry overnight before cutting on the saw.
Cutting wet or newly glued wood can cause the safety system cartridge to activate and stop the blade. If this happens, the member responsible shall replace the cartridge and the sawblade at their own expense.
- **Do not touch the blade while there is any motion of the blade.**



GENERAL SAFETY GUIDELINES – see General Power Tool Safety Guidelines

MACHINE SPECIFIC GUIDELINES

- **Report all problems to the supervisor.**
- Think through an operation before performing it. Know what you are going to do, what the machine can do, and where your hands and workpiece will be.
- Check wood for metal with a WEC metal detector and remove dirt and dust with wire brush.
- Keep fingers at least 6 inches from the blade.
- Use push block/stick on all rip cuts less than 6” wide.
- Do not overreach or stretch to get something.
- Turn off saw and let blade stop to remove debris, cut offs, shims, etc.
- Set blade height to expose the saw blade gullet of the blade teeth over the workpiece at the highest point of travel of the teeth, exposing 5-7 teeth, depending on the blade type.
- Do not use the rip fence as a stop for cutting wood to length. The piece could get hung up and fly back at you or someone else in the shop, possibly causing serious injury.
- The doors on Sawstop must be closed to operate the saw (there are three doors – left side of saw, right side of saw, and under the insert).
- Note: dust collection blast gate will remain open for 50 sec after machine is powered down.
-

DEMONSTRATE THE FOLLOWING

- Checking work piece for metal with a WEC metal detector and remove dirt and dust with wire brush.
- The location of all table saw machine controls.
- Changing the blade and installing the correct blade for an operation.
- Using a push stick for moving work piece through the blade.
- Cross cutting operations (using the **miter gauge** and a **saw sled**).
 - This is to square the end of a workpiece and/or cut it to length.
 - Use a crosscut or combination blade.
 - **Demonstrate drawing a reference line** on the workpiece.



- **Demonstrate use of the miter gauge**
- One hand is on the miter gauge handle and the other is holding the wood secure. The hand on the handle pushes the workpiece into and through the saw blade.
- Always check to see if the miter gauge is square to saw blade. Use a square or plastic drafting square. Make sure the blade of the square rests on the saw plate, not on plate and one of the saw teeth.
- **Demonstrate** how to use the fence as a stop for multiple lengths. Will need a block of wood and clamp.
- **Demonstrate use of a saw sled** for cutting wide and long pieces **Note:** Wide and long pieces should be cut on a **saw sled**.
- **Note:** A saw sled can allow you to cut long or wide pieces of wood. It can also help cut multiple pieces of the same length. Get help or devise support long pieces of wood. Hand placement on the saw sled is the same as the miter gauge. One hand on the saw sled pushes the wood through saw blade, the other hand holds the stock secure. Do not place your hands in the area of the yellow warning tape on the sled.
- **Demonstrate** setting up stop blocks for multiple cuts of same length, and where to store them. Point out where sawdust can build up against stop block and cause pieces to be shorter than desired.
- Rip sawing operations:
 - Process in which wood material is cut along the grain to desired width assuming one edge of stock is square and straight.
 - Check and make sure the proper blade is installed in the saw (rip saw blade).
 - **Demonstrate** how to check for saw blade square to table.
 - **Demonstrate** how to set fence to desired width.
 - Use push stick/block when rip is less than 6" wide.
 - Show different types of push stick/blocks and where they are stored.
 - **Demonstrate** ripping operation.
 - Discuss kickback and how to deal with it.
 - **Demonstrate** the use of a feather board, magnetic or other type.

ADVANCED OPERATIONS – see the supervisor.

- Spline jig.
- Tenon jig.
- Miter gauge angle cuts.
- Angled rip/crosscut with saw blade tilted.
- Resawing operations or other types of jigs.



CLEAN UP:

- Make sure dust tube is still connected to dust ports inside base cabinet.
- Remove insert and blow off top of arbor assembly.
- Blow off fence area and tabletop, the base cabinet and sweep up.
- Lower the saw blade below the blade insert and place fence over of insert.

SUMMARY OF TABLE SAW TRAINING REQUIREMENTS

#	Training Requirement	Complete
1	Identify the location of all table saw controls	
2	Check workpiece for metal; clean wood before sawing	
3	Changing, installing the correct blade	
4	Use of push sticks for moving piece through saw	
5	Cross cut: draw reference line on workpiece	
6	Cross cut: demonstrate use of the miter gauge	
7	Cross cut: use of fence as stop for multiple cuts	
8	Cross cut: use of a saw sled	
9	Cross cut: set up stop block on sled for multiple cuts	
10	Rip cut: check for saw blade square to table	
11	Rip cut: set fence to desired width of cut	
12	Rip cut: make a rip cut on a workpiece	
13	Rip cut: use of feather board - workpiece against fence	
14	Discuss clean up procedures	



Dado Saw

NOTE: Must be trained on table saw first.

INTRODUCTION

The WEC dado saw consists of a Sawstop table saw, like the regular sawing Sawstop, that is fitted with a **dado set** of cutters. As the dado set spins, the two outside blades cut the dado walls, and the chippers remove the waste material in between and smooth the bottom of the dado. Consequently, changing the dado width requires the complete removal of the dado blade set from the arbor to add or remove components. The Sawstop table saw used as the Dado Saw has the same controls, safety, and warnings as the sawing Sawstop. The Dado Saw is equipped with a **set of custom blade inserts** to make the clearance between the blade set and the insert is as small as possible.



Watch a short video at the QR code or URL on table saw dado operations.



URL: <https://www.youtube.com/watch?v=SrRGLCWBf4w&t=306s>



Operations	Hazards
Dado Cuts	Kickbacks
Groove Cuts	Chipping
Rabbet Cuts	Blade heating
	Hand injury

SAFETY GUIDELINES – see Power Tool Safety Guidelines

ADVANCED OPERATIONS – see the supervisor

- Half lap joints
- Tenon
- Slotted dados
- Box Joints

CLEAN UP:

Remove insert and blow off top of arbor assembly.

Blow off fence area, tabletop, and the base cabinet and sweep up.

Lower dado blades below insert and place fence over of insert

SUMMARY OF DADO SAW TRAINING REQUIREMENTS

#	Training Requirement	Complete
1	Identify the location all dado saw machine controls	
2	Set up saw blade stack and explain the use of shims	
3	Explain the various types of cuts: dado, groove, rabbet	
4	Set up a rabbet with sacrificial fence	
5	Usings feather boards as hold down devices	
6	Discuss clean up procedures	



Power Miter Saw

INTRODUCTION

A power miter saw is used to make quick, accurate crosscuts in a workpiece at a selected angle. Most miter saws are relatively small and portable, with common blade sizes ranging from 8 to 14 inches. A distinguishing feature of the power miter saw is the *miter index* that allows the angle of the blade to be changed relative to the fence. While most miter saws enable precise one-degree incremental changes to the miter index, many also provide "stops" that allow the miter index to be quickly set to common angles (such as 15°, 22.5°, 30°, and 45°).



Machine Nomenclature:

Dewalt 12 inch

Watch a short video at the QR code or URL on power miter operations.



URL: https://www.youtube.com/watch?v=QRpR1o8NS_I



Operations	Hazards
Crosscutting at various angles	Kickback Free handing cuts Flying chips Cuts, lacerations, amputation

GENERAL SAFETY GUIDELINES – see General Power Tool Safety Guidelines

MACHINE SPECIFIC GUIDELINES

- **Report all problems to the supervisor.**
- Keep fingers and other body parts at least 3” from blade.
- Do not reach underneath the running saw.
- Never lock the switch to “on”.
- Properly support long stock.
- Never cut small pieces that would require to put fingers within 3” of blade.
- Allow motor to come to full speed and vacuum to come on before cutting wood.
- Always have wood on table and against fence. (Talk about bowed or curved wood stock.)
- Ease the blade through the cut. Let the tool do the work.
- After completing the cut, do not raise the blade from wood until you turn off saw and let spin to stop.
- When cutting miter on upright stock, clamp to fence. The saw tends to move the wood if handheld.
- The saw has a laser guide. If the laser is not working notify the supervisor.



DEMONSTRATE THE FOLLOWING

- The location of all power miter saw machine controls.
- Marking a square line on wood.
- Cutting wood.
- Changing angles and cutting stock.
- Proper cuts on a work piece with a crown or twist.

CLEAN UP:

- Blow dust off miter saw and table behind saw and underneath the saw to floor and sweep up.
- Report problems to supervisor.

SUMMARY OF POWER MITER SAW TRAINING REQUIREMENTS

#	Training Requirement	Complete
1	The location of all power miter saw machine controls	
2	Mark a square cut line on a workpiece	
3	Line up the blade with the cut line	
4	Make a cut	
5	Use a clamp to secure workpiece to the fence	
6	Change blade angle and making a miter cut	
7	Make cuts on workpiece with a crown or twist	
8	Discuss clean up procedures	



Jointer

INTRODUCTION

Jointers are machines used to prepare stock for making joints and smoothing the edge or surface of stock. They have high speed rotating knives that remove material as it is pushed past the rotating head.

Parts of a Jointer:

- Fence
- Tables: infeed and outfeed
- Cutterhead and guard
- Height adjustment, height indicator
- Base with motor



WEC Machine Nomenclature

Bridgewood Model BW-12J 12”

Jointer

Powermatic Model 60 8” Jointer

Watch a short video at
the QR code or URL
on jointer operations.



URL: <https://www.youtube.com/watch?v=gfGRW9VIWkl>



Operations	Hazards
Surface planing Edge planing	Noise Lacerations and amputation of fingers Loose hair or clothing

GENERAL SAFETY GUIDELINES – see General Power Tool Safety Guidelines

MACHINE SPECIFIC GUIDELINES

- **Report all problems to the supervisor.**
- Keep fingers 6 inches away from cutter head.
- Never put your hands over the cutter area.
- Always use push blocks/sticks to move stock over cutterhead.
- Stock should be 12” minimum in length and 1/2” or thicker.
- Check wood for metal with a WEC metal detector and remove dirt and dust with wire brush.
- Note: dust collection blast gate on Powermatic jointer will remain open for 50 sec after machine is powered down.
- Flattening a piece of stock (planing):
 - Demonstrate with relative flat stock.
 - Use chalk (in crisscross grid pattern) to help see when enough material has been removed to flatten stock.
 - Check stock for cup, twist, and bow.
 - Feed cup through jointer with humped side up.
 - Feed bowed stock with hump up.

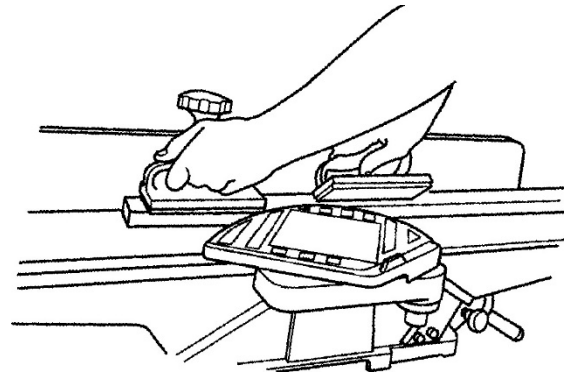



- Twist is hard to flatten. Hold on end of stock flat to bed and keep pressure on this end through the cut. Lightly hold stock at rear enough to push through. If full pressure is transferred to the rear you can end up with a planed, but still twisted stock.
- Always put stock on the bed and see if there are gaps or rocking. If so, keep on working stock until flat.
- If you have stock with cup, twist and bow be content with a flattened piece that might be thinner than what you need or dispose of as not usable.
- Option for severely bowed stock – use a straight edge or chalk line to make a straight guideline on across the bowed section of the stock. Use a bandsaw and the guideline to cut out most of the bow and use the joint to finish the surface.
- If the full length of the stock is not needed, cut stock into smaller but usable sizes. This may allow for thicker stock in the case of a severe bow.

- Jointing stock

- Jointing is the removal of wood along one edge of a piece of stock to make the edge straight, smooth, and square to flattened face. The flattened face must be held flat against fence throughout entire cut.
- Hold the board firmly down and flat against fence. Keep your fingers close together. Feed the board at a continuous rate of speed until the cut is made along the entire length of board. A chalk line run down the length of edge will help show when edge is straight.
- Do not feed too fast. A slow steady rate of feed produces a smooth accurate cut. Feeding too fast causes a “rippled” cut, makes it difficult to guide the board accurately, and can be dangerous.

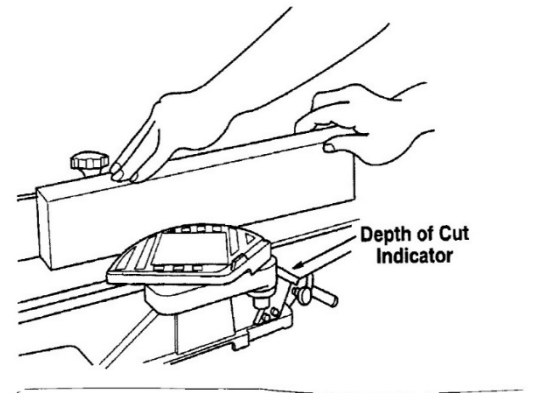



- Feed with the grain whenever possible. If you can't, take very light cuts and feed slowly.

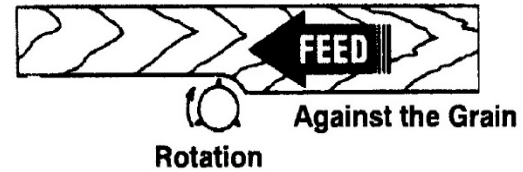
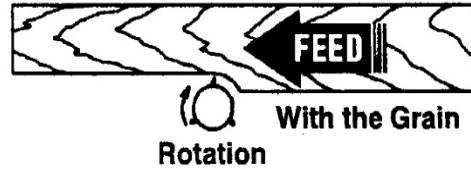

- Support long pieces. Show where supports are stored. Do this whenever the board tilts up from the cutterhead and you can't hold down.

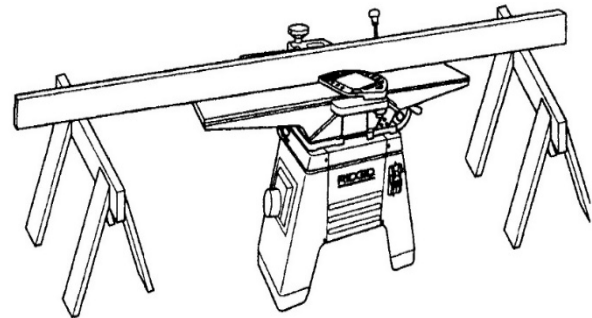

ADVANCED OPERATIONS – see the supervisor.

- Bevel cuts.
- Report any problems to supervisor.
- When in doubt consult the supervisor and or manual.

CLEAN UP: Blow chips and dust off machine and sweep up.

SUMMARY OF JOINTER TRAINING REQUIREMENTS

#	Training Requirement	Complete
1	Identify the location all jointer machine controls	
2	Check stock for metal, remove dirt with wire brush	
3	Turning on and shutting off the jointer	



#	Training Requirement	Complete
4	Ensure fence is in locked position before use	
5	Check that fence is square with table(s) before use	
6	Check cutter guard is free to open and close before use	
7	Flattening a piece of stock (planing)	
8	Jointing the edge of a piece of stock	
9	Explain feeding stock with the grain	
10	Discuss clean up procedures	

Thickness Planer

A thickness planer is a woodworking machine used to trim boards to a consistent thickness throughout their length and flattening boards on both surfaces. The thickness planer is like a jointer in that it removes material from the surface of a board. It is different from a jointer (or surface planer) in where the cutter head located: above the feed table. The feed table on a thickness planer is shorter and wider than the table of the jointer. The main advantage of the thickness planer is consistent board thickness. The main advantage of the jointer is preparation of the first flat surface of the board.



Parts of Thickness Planer:

- Head assembly
- Feed Table.
- Hand Wheel for depth of cut adjustment.
- Column and locking handles.
- Stand and motor.

Machine Nomenclature

- Grizzly 20" planer
- Jet 20" planer

Watch a short video at the QR code or URL on thickness planer operations.



URL: <https://www.youtube.com/watch?v=bQ8QgFZ5b9g&t=5s>



Operations	Hazards
Flat parallel surfaces	Clothing or hair entrapment Objects thrown from machine Nip points from rotating parts Noise

GENERAL SAFETY GUIDELINES – see General Power Tool Safety Guidelines

MACHINE SPECIFIC GUIDELINES

- **Report all problems to the supervisor.**
- Keep hands, fingers, and clothing away from feed rollers.
- Keep your hands away from feed rollers while operating.
- Minimum length of stock to run through the planer is 8”.
- Check stock for metal and remove dirt and dust with wire brush.

GUIDELINES WHEN USING THICKNESS PLANER

- Prepare one board surface with the jointer before going into planer. The planer will flatten the wood by force but not take out any cup, twist, or bow.
- Measure thickness of board in several places and set to thickest part of wood.
- Make passes through the thickness planer of **no more than 1/32”**. This is half a turn on hand wheel. Sneak up on final thickness.
- Proper feed into planer: feed middle, left, then right, etc., for even wear of cutters.
- If planer gets stuck lower the table/bed until wood passes through.
- Be careful pushing wood into the feed rollers as it may pop up then snap down pinching fingers. Push down on wood at the of the feed table as it is being fed into the planer.

CLEAN UP:

Blow off all debris from top, table and stand, then sweep up.



SUMMARY OF THICKNESS PLANER TRAINING REQUIREMENTS

#	Training Requirement	Complete
1	Locate all thickness planer machine controls	
2	Check wood for metal with metal detector, remove dirt with wire brush	
3	Explain jointer pre-step before thickness planing	
4	Run stock through planer down to specified thickness	
5	Discuss clean up procedures	

Drill Press

INTRODUCTION

A drill press is a fixed style of drill that may be mounted on a stand or bolted to the floor or secured to a workbench. A drill press consists of a base, column (or pillar), table, spindle, quill, and drill head with spindle pulleys (to vary drill speed) plus motor. The head has a set of handles (usually 3) radiating from a central hub that, when turned, move the spindle and chuck vertically, parallel to the axis of the column. The table can be adjusted vertically and is generally moved by a rack and pinion.



Machine Nomenclature

Woodtek Drill Press

Jet JPD-17

Watch a short video at the QR code or URL on drill press operations.



URL: https://www.youtube.com/watch?v=Gq8jL_ZDjNM

Control switch – turns power on and off.

Head – contains belt system for speed control.

Quill – vertical sleeve moving up and down containing rotating shaft to which chuck is attached.

Depth stop – sets the depth where the bit stops.

Belt/pulley system/tensioner – system that adjusts the bit speed.

Table – a flat table that supports the work and moves/tilts to position the work.

Column – vertical shaft supporting the table and head.

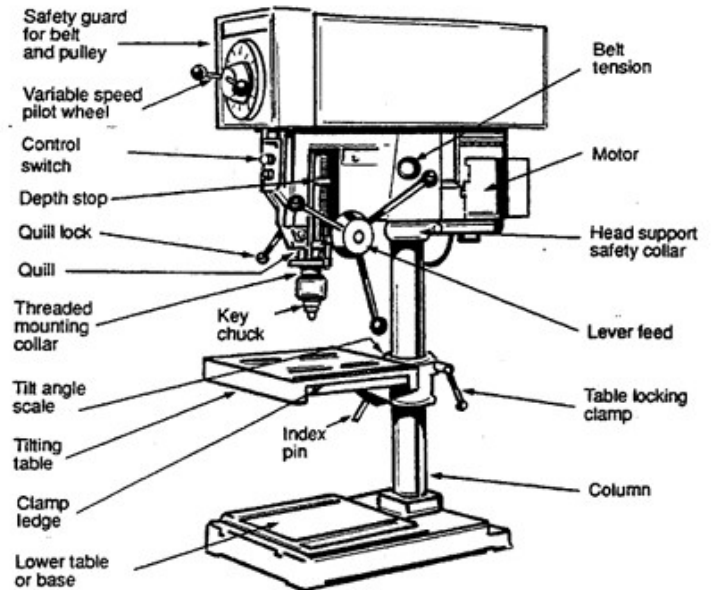

Diagram of a Typical Drill Press

GENERAL SAFETY GUIDELINES – see General Power Tool Safety Guidelines

MACHINE SPECIFIC GUIDELINES

- **Report all problems to the supervisor.**
- Keep hands at least 3 inches from drill press bit/chuck.
- **Clamp work to table or use fence to restrict movement of workpiece.**
- Don't use your hand to sweep off wood shaving from underneath the drill bit (rotating or not).
- Keep hands and fingers at least 3" from rotating drill bit.
- Never reach around or under a rotating drill bit.
- Turn off drill press before looking up or around shop.



- Never stop rotation of the drill chuck, spindle or rotating stock hung up on drill bit with your hand.
- Keep a tight grip on the chuck key when tightening drill chuck.

ADVANCED OPERATIONS – see the supervisor.

- Sharpening dull bits (optional).

CLEAN UP:

- Clean off the entire drill press when done using. (Don't forget the top of the belt cover)
- Blow out dust from fan cover of motor.
- Blow out dust and debris from belt area.
- Sweep up.

SUMMARY OF DRILL PRESS TRAINING REQUIREMENTS

#	Training Requirement	Complete
1	Locate all drill press machine controls	
2	Identify types of drill bits	
3	Use speed chart to determine proper drill bit speed	
4	Change bits and locate where chuck key is stored	
5	Change belts for proper speed on both types of drill presses	
6	Move table up and down and lock table	
7	Drilling: use of center punch to start hole (twist drill)	
8	Drilling: use of backer board to reduce tear out	
9	Drilling: frequent raising of bit for cooling and removal of shavings	
10	Set drill press depth stop	
11	Use the fence for drilling multiple holes	



#	Training Requirement	Complete
12	Proper cleaning of drill bit	
13	Discuss cleanup procedures	



Oscillating Spindle/Disk/Belt Sanders

INTRODUCTION

These sanders are for surface or edge sanding of nonmetallic materials only. The machines may be used for many types of rough, end grain sanding and simple shaping. The combination belt/disc sander is configured with a sanding disc and belt, and some may be individual units. The Edge belt sander will typically have only a belt but may oscillate vertically and have one or more worktables attached. The safety concepts presented are the same for any size machine.



Rikon Model 50-112 Belt/Disc Sander

Watch a short video at the QR code or URL on oscillating sander operations.



URL: <https://www.youtube.com/watch?v=3UQGikBrJul>



Operations	Hazards
Smoothing curves	Dust inhalation
Cleaning up bandsaw work	Finger entrapment
Smoothing edges	Finger abrasion

GENERAL SAFETY GUIDELINES – see General Power Tool Safety Guidelines

MACHINE SPECIFIC GUIDELINES

- **Report all problems to the supervisor.**
- Always maintain a balanced stance when operating these machines.
- Don't lean against the sanding machine when using.
- Always hold wood firmly when sanding with machine.
- Use fences and stops.
- Do not sand pieces that are too small to be safely supported or held.
- Always work on the downward side of rotating disc sander.
- Allow the motor to come up to speed before feeding material.
- Do not force material, let the tool do the work.
- Note: dust collection blast gate will remain open for 50 sec after machine is powered down.

ADVANCED OPERATIONS

- Any ripped belts or discs should be reported to the supervisor.
- Report all problems to supervisor.

CLEAN UP:

- Use sanding stick to clean sanding surface off when task is completed.
- Blow off dust and grit to floor and sweep up.



SUMMARY OF SANDER TRAINING REQUIREMENTS

#	Training Requirement	Complete
1	Locate all sander machine controls	
2	Check integrity of belt tracking and/or disc	
3	Demonstrate proper way to sand on various sanding machines	
4	Clean sanding surface frequently with cleaning stick	
5	Discuss clean up requirements	

Drum Sander

INTRODUCTION

A Drum Thickness Sander, also known as a “drum” sander is like a thickness planer in that it removes material from the surface of a board. However, instead of using a series of rotating knives and shaving the wood surface, it uses sandpaper attached to a drum to abrade the surface. The sanding drum spins above the workpiece that feeds the wood through the machine on a conveyer belt. A special feature found on some drum sanders is an open side that allows workpieces wider than the drum to pass through.

Machine Nomenclature

Jet 22-44

SuperMax



Watch a short video at the QR code or URL on drill press operations.



URL: <https://www.youtube.com/watch?v=ctufgksX3zU>



Operations	Hazards
Sanding wide panels	Dust inhalation
Making uniform thickness	Loose clothing getting caught in machine
Sanding delicate parts	Exposing hands to workpiece feeding process
	Flying objects

GENERAL SAFETY GUIDELINES – General Power Tool Safety Guidelines

MACHINE SPECIFIC GUIDELINES

- **Report any and all problems to the supervisor.**
- Do not stand in front or back while feeding stock through the sander.
- A pinched finger can occur if pushing stock into drumhead, the piece might lift then snap down.
- Before operation:
 - Check the condition and cleanliness of the sander and feed belt. Clean sander belt with a sander cleaning stick. Blow off dust from feed belt with air hose.
 - Set height of drumhead before feeding stock. It is best to set high and sneak up on the setting until wood starts to be sanded.
 - The sander drum is normally equipped with 120 grit paper meant for light surfacing and minimal stock removal. The maximum depth of cut is 1/128", or 1/8" turn of height adjuster.
 - Make sure dust system is on and open blast gate.
 - Turn on drumhead.
 - Turn on the feed belt.
- During operation:
 - Only make small height adjustment of 1/8 turn of wheel.
 - Sometimes reverse stock end for end and run through without any height adjustment.
 - Use the whole feed area on the table, not just the middle.



- Watch for stock not gripping the feed belt. Push down with palm of hand to help move through sander. Sometimes this must be done on the front and back of feed.
- Frequently stop sanding and open top cover and use sanding cleaner stick to clean sanding belt.

- When done.
 - Turn off the feed belt.
 - Turn off drumhead.

ADVANCED OPERATIONS – see the supervisor.

- Changing sanding belt.
- Edge sanding operations.
- Using oscillating feature.
- Using a backer board for thin pieces.

CLEAN UP:

- Clean drumhead sanding belt while running with sanding cleaning stick.
- Blow off all dust and debris, inside and out.
- Start feed belt and blow off dust for one full revolution covering the entire surface of feed belt. Removal of dust will help the belt grip wood better.
- Close dust collector gate.
- Sweep up.



SUMMARY OF DRUM SANDER TRAINING REQUIREMENTS

#	Training Requirement	Complete
1	Locate all drum sander machine controls	
2	Check cleanliness of drum and use of cleaning stick	
3	Set proper height of drum and identify max depth of cut	
	Set proper feed belt speed	
4	Sand a workpiece of normal thickness	
5	Sand a thin workpiece with a sanding board	
6	Discuss clean up procedures	



Handheld Router

INTRODUCTION

The router is a power tool with a flat base and a rotating bit extending past the base. The spindle is driven by an electric motor. It routs (hollows out) an area in hard material, such as wood or plastic. Routers are used frequently in woodworking, especially cabinetry. They may be handheld or affixed to router tables. Most woodworkers consider the router one of the most versatile power tools.



Machine Nomenclature

Porter Cable 7529 Plunge Router

Porter Cable 7310 Trim Router

Porter Cable 690

Watch a short video at the QR code or URL on handheld router operations.



URL: <https://www.youtube.com/watch?v=mclBmdYs5iU>



Operations	Hazards
Cutting Shaping Trimming	Noise Improper chucking of bits Flying chips Sawdust inhalation Incorrect routing direction

GENERAL SAFETY GUIDELINES – see General Power Tool Safety Guidelines

MACHINE SPECIFIC GUIDELINES

- **Report all problems to the supervisor.**
- Keep your fingers at least 3 inches away from the router bit.
- Router bits are sharp and can cut severely. Handle with care.
- Safety glasses must be worn.
- Dust protection is highly recommended.
- Hearing protection shall be worn.
- Make sure router is turned off before plugging in.
- Workpiece must be clamped down if using a handheld router.
- Never start router with bit in contact with wood.
- Let router get up to full speed before starting cut.
- Hold router firmly.
- Let router bit come to a stop before setting down.
- Always consult router how-to book in library or how-to video on YouTube for unfamiliar router operations.



Router feed direction based on rotation direction of router bit.

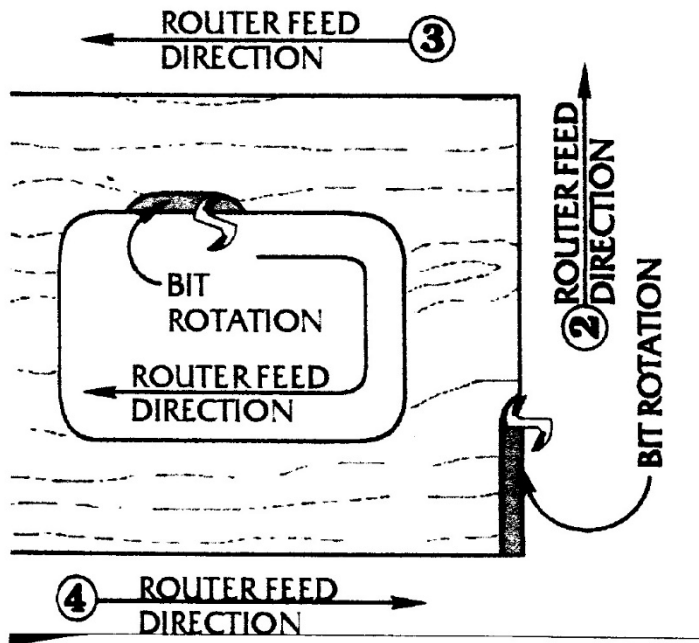

ADVANCED OPERATIONS – see the supervisor.

- Cutting circles and ovals.
- Plunge routing.
- Dado and groove cuts.
- Rabbet and fillister cuts.
- Using edge guide.
- Mortises.

CLEAN UP:

- Blow area of operation clear of debris.
- Blow out/off router, especially the motor vents.
- Sweep up.



SUMMARY OF HANDHELD ROUTER TRAINING REQUIREMENTS

#	Training Requirement	Complete
1	Locate all handheld router machine controls	
2	Select and inspect a router bit	
3	Install a bit into the router	
4	Demonstrate a profile routing operation	
5	Demonstrate a flush trim routing operation	
6	Remove bit from the router	
7	Demonstrate cleaning a router bit	
8	Discuss cleanup operations	

Router Table

INTRODUCTION

A router table is a stationary woodworking machine in which a vertically oriented spindle of a woodworking router protrudes from the machine table and can be spun at speeds typically between 3000 and 24,000 rpm. There are two common ways to configure a routing table: with a fence against which the workpiece moves, and without a fence but guided by a ball bearing mounted on top of the router bit that follows the outline of the workpiece.

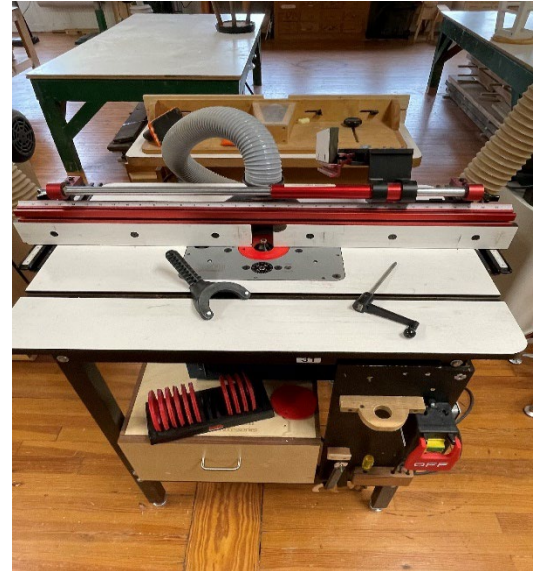

Machine Nomenclature

JessEm Router Table

Porter Cable 890 Series Router

Watch a short video at the QR code or the URL on router table operations.



URL: <https://www.youtube.com/watch?v=jamwRhQTJbA>



Operations	Hazards
Cutting	Noise
Shaping	Improper chucking of bits
Trimming	Flying chips
Milling grooves, dados, slots	Sawdust inhalation
Stopped cuts	Incorrect routing direction
Cope and stick joinery	Trapping stock between bit and fence
	Routing small parts

GENERAL SAFETY GUIDELINES – see General Power Tool Safety Guidelines

MACHINE SPECIFIC GUIDELINES

- **Report all problems to the supervisor.**
- Keep fingers and hands away from router bit by 3”.
- Use push block to protect hands from router bit.
- On narrow pieces use feather boards and/or push blocks.
- Properly support long pieces.
- Always feed against rotation of bit.
- All pieces are fed from right to left when standing in front of the table.
- Never trap stock between fence and bit.
- Open the blast gate before use.

GUIDELINES DURING OPERATION

- Installing a router bit
 1. Install proper size chuck/collet (depending on shank size of bit) on the router shaft.
 2. Clean and insert the shank of the bit into the collet until the shank bottoms, then back it out approximately 1/16”.
 3. Place one wrench on the router shaft flats holding the shaft still.



4. Place the other wrench on the chuck and tighten COUNTER-CLOCKWISE. Tighten firmly.
 5. To remove the bit, reverse the procedure.
- Show where to check for router speed.
 - Line up bearing of router bit with fence.
 - Adjust fence halves so the cutter opening clears both halves.
 - Adjust router bit to desired height. (On router lift make sure lift is unlocked.)
 - Run a sample piece and check if height of bit is ok, if not adjust height. (On router lift engage the lock).

ADVANCED OPERATIONS – see the supervisor.

- Dado operations
- Horizontal router table.
- Free hand work.
- Blind router cuts.
- Stopped router cuts.
- T-slot cutting.

CLEAN UP:

- Unplug. Remove cover ring.
- Unlock router lift, remove router bit, clean bit with WD-40 and wipe clean. If residue can't be removed have the supervisor show you how to use Rockler cleaning solution. Always remove the bearing before going onto cleaning solution.
- Put router bit back in its proper place in drawer.
- Open door on dust deputy and clear out debris, blow clean.
- Blow off router motor.
- Sweep up.



SUMMARY OF ROUTER TABLE TRAINING REQUIREMENTS

#	Training Requirement	Complete
1	Locate all router table machine controls	
2	Install proper size chuck/collet	
3	Clean and install bit into the collet	
4	Check for router for speed	
5	Align fence and fence halves with bit	
6	Adjust router height	
7	Run work piece through the bit; adjust height for additional passes	
8	Discuss cleanup operations	

Bench Grinder and Tool Sharpening

INTRODUCTION

A **bench grinder** is a benchtop type of grinding machine used to drive abrasive wheels. Depending on the bond and grade of the grinding wheel, it may be used for sharpening cutting tools such as tool bits, drill bits, chisels, lathe tools. A wire brush wheel or buffing wheels can be interchanged with the grinding wheels in order to clean or polish workpieces. **Sharpening** tools well is one of the most important skills a woodworker must acquire. A grinding fixture or **jig** is often needed to present the tool to the grinding wheel with a repeatable geometry. This helps minimize wear to both the grinding wheel and the tool and achieves a superior cutting edge with minimal effort.



WEC Machine Nomenclature

Porter Cable 8" Bench Grinder

Oneway Wolverine Grinding Jig

Oneway Vari-Grind Jig

Watch a video at the QR code or URL on bench grinder operations.



URL: <https://www.youtube.com/watch?v=GB-Pa73Snp4>



Operations	Hazards
Grinding	Flying chips
Sharpening	Sparks
Buffing	Heating

GENERAL SAFETY GUIDELINES – see General Power Tool Safety Guidelines

MACHINE SPECIFIC GUIDELINES FOR BENCH GRINDER

- **Report all problems to the supervisor.**
- Keep your fingers at least 2 inches away from the grinding wheel.
- Keep the tool rest at least 1/8 inch away from the grinding wheel.
- Inspect the grinding wheels for cracks.
- Make sure wheel housing guards are in place.
- Do not operate the grinder unless securely mounted to the workbench.
- Do not operate the grinder without a tool rest.
- Do not grind on the side of wheel.
- Safety glasses/face shield shall be worn.
- When turning off grinder, **let it come to a full stop before leaving area.** Never use an object to slow the grinder to a stop.
- Use only high-speed steel (HSS) tools on lathe tool grinder.
- No contouring of stones for special grinds.

For all grinders:

- All adjustments to the grinder must be made with the grinder stopped and unplugged from electrical power.
- Stand to one side when turning on power.
- Keep container of water handy to cool blade. This should be done regularly during sharpening.



ADVANCED OPERATIONS – see the supervisor.

- Special training is needed in sharpening lathe tools.
- *The Complete Guide To Sharpening*, Leonard Lee (in the WEC Library)

SHARPENING TOOLS

Learning to sharpen your tools is a necessary skill to have and the Guild recommends you learn this skill early on. It will save lots of time if by using well sharpened tools yielding cleaner results. Here are some good videos to watch to help you get started.

Basic tool sharpening



URL: <http://www.youtube.com/watch?v=jwwD4Xzwe7k>

Sharpening lathe tools with the Wolverine Sharpening System



URL: <https://www.youtube.com/watch?v=31pzViUhJuQ&t=12s>



SUMMARY OF BENCH GRINDER TRAINING REQUIREMENTS

#	Training Requirement	Complete
1	Locate all bench grinder machine controls	
2	Inspect grinding wheel for cracks and wobble	
3	Flattening the grinding wheel	
4	Setting the tool rest	
5	Explain result when steel turns blue and how to correct	
6	Discuss cleanup operations	



Lathe

Introduction

A wood lathe is a powered machine tool that rotates a workpiece about an axis parallel to or at right angles with the base of the lathe.

Lathes can be used to create functional furniture components, beautiful decorative wood projects such as candlesticks and bowls, or even toys such as tops and yo-yos. These machines range in size from hobby models that fit on a workbench to large industrial-sized machines weighing hundreds of pounds, but they all share some basic elements. Rotating speeds range from 200 to 4,000 rpm.



WEC Machine Nomenclature

Delta midi lathe 46-250

Delta midi lathe 1a200

Jet 1642 lathe

Rikon 70-100 lathe

Powermatic lathe

Watch a short video at the QR code or URL on lathe operations.



URL: <https://www.youtube.com/watch?v=jcokD6zRyrw>



Operations	Hazards
Spindle turning	Entanglement
Faceplate turning	Objects thrown off lathe.
Chuck turning	Kickback
Polishing	Dust inhalation
Sanding	Burns

GENERAL SAFETY GUIDELINES – see General Power Tool Safety Guidelines

MACHINE SPECIFIC GUIDELINES

Before starting lathe, go through the following checklist:

- **Report any and all problems to the WEC supervisor.**
- Check for loose clothing.
- Tie back long hair.
- Safety glasses with side shields and a face shield shall be worn.
- Are tools sharp and in good condition.
- Is tool rest smooth.
- Check turning stock for soundness.
- Is turning stock secure in lathe (check for knots, splits, irregularities).
- Rotate stock by hand, make sure it clears tool rest.
- Check turning speed before starting lathe.
- Position the tool rest a little below center of the workpiece and no further than 1/8 inch from the work as workpiece diameter decreases.

During operation

- Never adjust the position of the tool rest while the lathe is running.
- Never leave the lathe running unattended.
- Approach your work on the lathe with a cautious safety attitude.
- Rough out your workpiece on a bandsaw before mounting it on the lathe.



- Snug the tailstock center against the work and lock it. Lubricate the tailstock center if it is not a ball-bearing center.
- Hold turning chisels securely on the tool rest and hold the tool firmly. Always use a slower speed when starting until the workpiece is cylindrical. This helps avoid the possibility of an unbalanced piece jumping out of the lathe and striking the operator.
- Keep the woodturning tools sharp. A dull chisel requires that you apply excessive feed pressure.
- Contact the work cautiously, and then slowly progress the cut more aggressively.
- Never use your fingers to check the work for roundness while the lathe is running, especially during roughing operations. Stop the lathe to check the progress or rest the blade of the tool lightly against the work as it turns.
- Clean up wood shavings and sawdust often. Sawdust can create a slipping hazard.
- Remove the tool rest before sanding or polishing on the lathe.
- When sanding, remember that the spinning stock will cause the sandpaper to heat up from the friction of sanding. So, sand on a low speed, on the back side of the stock on the down stroke.
- Disconnect the power source before making repairs.

ADVANCED OPERATIONS – see supervisor.

- Face Plate Turning
- Turning Objects with a 4-jaw chuck
- Sharpening gouge tools on a grinder.
- Use of bandsaw to remove corners from square stock prior to turning.

CLEAN UP:

Sweep up work area around lathe often. Lathe operations generate a lot of chips quickly that make for a slippery floor.



Additional information on wood lathe operations (provided by Lynn Smith)

Lathe Safety Tips. New wood turners need to know that there are some inherent safety risks involved with spinning a chunk of wood at more than 1,500 RPM. As a natural material, wood's grain pattern and strength are not necessarily consistent throughout most pieces of stock, and these pieces have been known to fail and fly off a lathe. For that reason, it's important to clamp a stock carefully at the dead center of the stock whenever possible.

Another lathe safety tip is to dress carefully. Lathes spin very fast and don't stop quickly, so getting a loose sleeve or long hair wrapped up can be disastrous. Be sure to avoid loose fitting clothing and keep hair tied neatly back.

Never adjust the tool rest while the lathe is running.

Finally, only use wood that appears to be in good condition, free from knots or cracks. Taking these safety precautions will help keep the user safe while turning.

Select the correct cutting tools for your objective. Lathe tools are called chisels. They feature long, round, curved handles to afford a solid grip and sufficient leverage to enable the turner to control the cutting edge accurately with minimal fatigue. Common wood chisels simply are too short and are ill-designed for this purpose. Here are a few of the many types turning tools you may find:

Gouges. These usually have specially shaped cutting edges for performing cuts, such as *bowl gouges*, with concave, curved cutting edges to form the smooth, curved surface of a bowl, or *vee*, or *knurling gouges* for cutting grooves or knurls in wooden spindles.

The spindle gouge is shaped to cut when spindle turning. The wood grain is running parallel to the lathe. The bowl gouge has a deeper flute to help the shavings leave the inside of a bowl. The spindle gouge has a shallow flute. Both gouges have the top corners of their flute ground away so that you can present the tool to the wood without catching on the tips. Take a close look at the roughing gouge and you will see almost a right angle at the tips.

Scrapers. These are often flat or slightly curved chisels for removing wood from flat or cylindrical shapes, or for *roughing out* a shape.

Parting tools. These are thin, vee tipped tools for cutting off work pieces.



Other tools you may encounter are skew chisels, fluted gouges, spindle gouges, and nose chisels.

Another lathe tool class is called carbide tools. There are some significant differences between carbide and high strength steel (HSS) tools (the traditional material for lathe tools). For first time wood turners, carbide tools may be quicker to learn than HSS tools, require virtually no maintenance (stay sharp longer and are throw-away when all edges are dull), and have much longer life than HSS tools. HSS tools are less expensive, can hold a much sharper edge, and have many more shapes and unique cutting edges than carbide tools. HSS tools tend to produce smoother finishes due to their cutting action (rather than scraping like carbide tools) which cuts down on finishing time and repair time to wood stock.

Read your owner's manual before proceeding with actual lathe work for specific instructions, features and detailed safety instructions. Keep your owner's manual handy for reference if you decide to purchase accessories for your particular lathe, for maintenance instructions, and for reference to capacities and specifications for your machine.

Learn the components of your lathe. A basic wood lathe consists of a bed, headstock, tailstock, and tool rest. Here are the functions of each of these parts.

The headstock consists of the drive train, including the motor, pulleys, belts, and spindle, and for a right-handed turner, will be located on the left end of the lathe. Mounted on the end of the headstock facing the tailstock is the spindle and the spur center or for face turning such as bowls and plates, or other *flat* or *face* work, the face plate assembly.

The tail stock is the *free spinning* end of the lathe, and has the tailstock spindle and the cup center, as well as a *hand-wheel* or other feature for *clamping* or securing the work piece between the lathe centers.

The tool rest is similar to a mechanical arm with a metal guide bar to support the chisel used for turning the work piece. It usually can be adjusted by sliding the length of the bed at its base, with an intermediate arm that can swing from a parallel to a perpendicular position in relation to the lathe bed, and the upper arm, which holds the actual tool rest bar. This assembly has as many as three *swivel joints*, all of which tighten with a setscrew or clamp to keep it secure while turning is in progress.



Two kinds of turning. When you put the turning blank on the lathe and the grain of the wood is parallel to the bed of the lathe then you are doing spindle turning. Your drive spur makes the wood spin, and the live center helps to hold it on the lathe.

It's important to clamp the blank as close to the center as possible on each end. Do this by using a pencil and a steel ruler.

Stretch the steel ruler from across two opposing corners and draw a line along the edge of the rule. Flip the steel ruler to the other two opposing corners and repeat. The two lines should intersect at the dead center of the blank. Repeat this process on the other end of the blank, as well.

When the grain of the turning blank is at right angles to the lathe then you are doing faceplate or bowl turning. There are different ways to hold your bowl blank on the lathe but one of the easiest is to mount your turning blank to a faceplate that is then threaded onto your drive shaft. The face plate is attached to the turning blank with wood screws.

Select a suitable piece of wood for your project. For a beginner, using a softwood like southern yellow pine, lodge-pole pine, or balsam fir may be a good idea. Look for a piece with straight grain, and few, tight, knots. *Never turn a split piece of stock, or one with loose knots*, these may separate during turning, and become projectiles traveling at a significant speed.

Anytime you hear a sound from your lathe that doesn't sound familiar, stop the lathe and make sure your turning is still attached securely. Tighten the tail stock, and any chuck you are using. You want that wood to stay on the lathe. Inspect the turning blank and make sure there are no cracks or splintered pieces of wood either.

Hand Positioning. One key to safe woodturning is to keep your hands in safe positions that will control the tool, but keep the fingers clear of the action. For right-handed wood turners, the left hand will be against the tool rest and the right hand will be holding the handle of the tool. Position the left hand so that the forefinger will be under the tool, resting against the side of the tool rest opposite the wood. The left hand's thumb will be on the top of the tool, helping to steady it against the forefinger and the tool rest.

The Tool Should Always Contact the Tool Rest. When turning, the gouge, chisel or scraper being used should always remain in contact with the tool rest. There is no such thing as safe "free handing" on a lathe. Ideally, the tool rest should be about a quarter inch away from the wood, and the cutting tool needs to be in contact with the tool rest before it meets the wood.



Additionally, there should be a limited distance between the point where the tool meets the tool rest and where it contacts the wood. The greater the distance between the two points of contact, the less support that is provided to the tool.

Use the Bevel. One key to safe woodturning is to remember to always keep the bevel behind the sharpened edge of the tool resting on the wood. Following this rule will help keep the tool from taking too much off at one time, or worse, grabbing the wood and perhaps ripping the tool out of the wood turner's hands.

When beginning to cut with a tool such as a gouge, while keeping the tool on the tool rest, lay the back edge of the tool onto the spinning wood so that the point of contact is on or behind the bevel, but that the tool's cutting edge is not yet cutting. Once contact is safely made, use your right hand to slide the tool backward (toward the body, away from the lathe) until the cutting edge begins to engage the wood. Throughout the entire cutting process, the bevel should remain in contact with the wood.

Cutters Lead and Scrapers Trail. When working with gouges, chisels, parting tools, and other cutters, the rear hand (the one on the handle) should always be lower than the forehand (on the tool rest). This will keep the tool in a leading position, where the wood will be turning into the cutting edge of the tool.

However, a scraper should be used in exactly the opposite manner. A scraper doesn't cut like a chisel but works more like a butter knife. As such, the rear hand should be higher than the forehand, which will allow the cutting edge of the scraper to be beneath the tool rest and be in a trailing position to scrape the wood.

Square the stock. For example, if you are going to begin with a piece of 2X4 lumber, rip it to a nominally square shape, such as 2X2. You can then chamfer, or bevel the square corners, effectively creating an octagonal piece, which will reduce the amount of wood that must be removed to reach your desired cylindrical shape.

Cut the stock to the desired length. For a beginner, starting with a relatively short length, less than 2 foot (0.6 m) long for an intermediate, or medium sized lathe, is a good choice. Longer work pieces are difficult to true, and maintaining a uniform diameter along the length of a longer piece can take a lot of work.

Mark the center of each end of your stock and position it between the lathe centers. Assuming the tailstock is not locked in position, slide this until it pushes the cup center into the tail end of your work piece. Using the hand crank, tighten the tailstock spindle so that it pushes the stock into the spur center, mounted on the headstock spindle. Make sure the work piece is securely held, and all clamps are



tightened, otherwise, the work piece may fly off the lathe while you are turning. Also make sure the lathe keys are out of the machine before you start.

Tool rest position. The tool rest is the part of the lathe where you rest your cutting tools, (skews, parting tools etc.). Ideally you want the tool rest to be as close as possible to the wood without touching it. It is best practice to check the wood by rotating it before turning the lathe on. If you turned the lathe on and the wood hits the tool rest, you could damage your tool or risk injury. Having the tool rest close to the wood also means the tools are less likely to be damaged, will work better and the wood turning will be more of a pleasure because you will not be fighting with your tools.

Making sure your tool rest is in a position where it can support your tool, introduce the bevel of the gouge before angling the handle up and introducing the cutting edge. It is highly recommended that you "work downhill", meaning cut from high points to low points. I would recommend using a stance where you can move easily allowing your body to move the tool rather than just your arms.

Never adjust the tool rest while the lathe is running.

Choose the chisel you will use for the turning operation. A *roughing gouge* is a good choice for beginning to turn an irregular or square work piece down to a round shape. Practice holding the tool on the tool rest, using your left (again, for right-handed persons) hand on the metal blade behind the tool rest, and your right near the end of the handle. Keeping your elbows *in* and braced against your body will give you better control of the tool.

Turn the lathe on; making sure it is at the lowest speed setting. Place the cutting edge of the tool on the rest, keeping clear of the rotating work piece, check your grip, and slowly begin *easing* it toward the work piece. You want to move in toward it perpendicular to the work piece, until the cutting edge just touches the wood. Forcing it or moving too quickly will cause the tool to jam into the wood, and it will either break off, or you will lose your grip on the tool if the lathe doesn't stall out. This is one of the most dangerous steps in beginning turning.

Feel the resistance of the cutting edge and watch the size of the chips being cut from the work piece. When turning, you will want to cut small chips, less than 1/4 of an inch in length.



Begin moving the cutting edge parallel to the rotation of the work piece, continuing to make a *light* cut along its length. When using a roughing gouge or similar tool, you can pitch the tool edge, so chips are thrown at an angle from the work piece, so you do not become covered with them while you turn. Twist the tool slightly and observe the flight path of the chips to adjust it so they fly away from you to your right or left.

Continue pushing the tool into the stock gradually, in *passes*, so that you remove a roughly equal amount of wood with each pass. This will eventually cut away the angular corners, leaving your work piece round, and with practice, cylindrical in shape.

Stop the lathe frequently when you are just beginning, to check your progress, look for stress cracks in the wood, and clear debris which may begin to accumulate on the lathe bed. You may want to use a pair of calipers to check the diameter of your work piece along its length so you finish with the desired diameter.

Smooth the finished round work piece by increasing your lathe speed, and holding your cutting tool so it barely contacts the wood, then moving it slowly along the work piece's length. The slower your tool moves, and *finer*, or lighter the cut, the smoother the finished cut will be.

Sand the work piece when you are finished cutting if desired. You can sand the stock by hand while it is turning if you use caution. Turn the lathe off, and swing the tool rest out of the way, then select a suitable grit and type of sandpaper for this process. Turn the lathe back on, and hold the paper lightly against the wood, moving it back and forth to prevent removing too much wood from one area of the work piece.

Practice Makes Perfect

As with any skill, it takes a lot of practice to become a good wood turner. An experienced wood turner makes it look easy, a point well taken by a beginner.

One thing almost every novice turner will notice is that they're so focused on following the above tips that they have a "death grip" on the tools. The grip on the tool should be firm and in control, but one should avoid "choking" the tool. After a bit of time on the lathe, the novice turner will begin to relax their grip on the tools, and at that point, they'll find woodturning becomes a little easier.



SUMMARY OF LATHE TRAINING REQUIREMENTS

#	Training Requirement	Complete
1	Locate all lathe machine controls	
2	Discuss proper safety gear for lathe operations	
3	Set up stock for spindle turning	
4	Check stock for soundness and mounting security	
5	Check and set up lathe turning speed	
6	Check tool rest for smoothness and clearance	
7	Demonstrate proper body stance and holding tools	
8	Make workpiece cylindrical with roughing gouge	
9	Obtain correct diameter with parting tool and caliper	



Scroll Saw

INTRODUCTION

A scroll saw is an electric saw useful for cutting intricate curves where a jigsaw or coping saw is not appropriate. It is somewhat like a band saw, but the bandsaw's blade is a continuous loop. Scroll saws use very thin saw blades like those used by coping saws and operate through a quick reciprocating up and down motion. This is probably one of the safest tools we have, but still there are a few cautionary steps to take.



Machine Nomenclature

DeWalt Scroll Saw DW788

Watch a short video at the QR code or URL on scroll saw operations.



URL: <https://www.youtube.com/watch?v=l67Ve7aWfDE>



Operations	Hazards
Intricate curve cutting Make small joints	Finger contact with blade Flying chips

GENERAL SAFETY GUIDELINES – see General Power Tool Safety Guidelines

MACHINE SPECIFIC GUIDELINES

- **Report all problems to the supervisor.**
- Do not start the motor with a blade in contact with wood.
- Hold workpiece firmly on table.
- When stopping work wait until the blade has stopped moving before removing scrap.
- Do not cut a work piece that does not have a flat bottom.
- Never back out of bound saw blade with machine on, turn off, wait until stopped, then back out.

Before operation:

- Install a blade:
- Turn off switch and unplug.
- Select blade.
- Make sure teeth on blade are pointed down and toward front of table.
- Tighten clamps securely on blade top and bottom.
- Set tension of blade.
- Set speed of scroll saw.
- If using a foot pedal, make sure on/off switch is in “on” position.
- Set the air hose to clear sawdust off piece.

After all operations are done.

- Move switch to “off” position.



- Release blade tension.
- Unclamp top of blade.
- Put support block under arm.

ADVANCED OPERATIONS – see the supervisor.

- Fretwork
- Angled table operation.

CLEAN UP:

- Blow of all dust and debris, top and underneath to floor.
- Sweep up.

SUMMARY OF SCROLL SAW TRAINING REQUIREMENTS

#	Training Requirement	Complete
1	Locate all scroll saw machine controls	
2	Identify the various blade types used	
3	Set tension on the blade	
4	Explain the use of the foot switch	
5	Explain the use of the arm support block	
6	Make cuts in work piece	
7	Back out of a cut	
8	Discuss cleanup operations	



Portable Power Tools and Hand Tools

INTRODUCTION

Portable power tools are designed for a wide variety of uses and are light and mobile. Examples are circular (skill) saws, jigsaws, drills, hammer-drills, sanders, grinders, routers. A hand tool is any tool that is powered by hand rather than a motor. Types of woodworking hand tools include saws, chisels, hammers, mallets, planes, and measuring tools such as squares and measuring tapes.

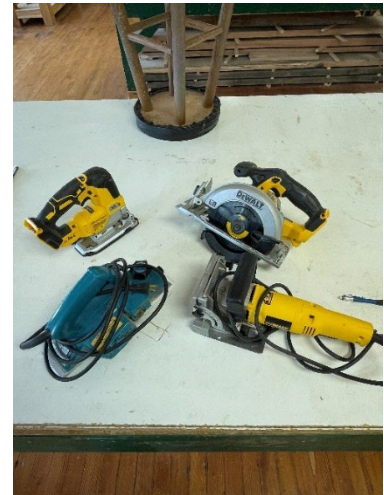

Hand tools and Portable Power Tools

- Cutting Tools
- Holding Tools
- Striking Tools
- Measuring and Marking Tools
- Fastening Tools
- Layout Tools

Watch a short video at the QR code or URL on hand-held tools.



URL: <https://thewoodwhisperer.com/videos/basic-tool-set-beginning-woodworker/>

Operations	Hazards
Cutting	Noise
Hammering	Improper chucking of bits
Grinding	Flying chips
Shaping	Sawdust inhalation
Jointing	



GENERAL SAFETY GUIDELINES – see General Power Tool Safety Guidelines

MACHINE SPECIFIC GUIDELINES

- **Report all problems to the supervisor.**
- Batteries on DeWalt tools. After use check battery charge. If two bars are visible, put them back on shelf, if only one bar is visible put in the charger.
- Show how to check battery charge and put it into charger correctly.

ADVANCED OPERATIONS – see the supervisor/mentor.

Consult Shop Supervisor before using unfamiliar small tools.

- Biscuit jointer
- Power planer
- Kreg jigs for pocket screws.
- Leigh dovetail jig.
- Tormek, Worksharp, and Drill Doctor sharpening tools
- Dremel tool

CLEAN UP:

Blow tools clean of all dirt and debris.

Clean up drill bits with WD-40, wipe dry and put back in proper place.

Sander Clean up:

- Remove sanding paper. If still usable put it back in proper slot.
- Clean out dust collection bags. Take outside and blow clean.
- Blow the tool clean of dust and debris.

Vacuums

- After use, check to see if it needs to be emptied or if the Filterpal and paper filter needs to be cleaned.
- After use all tools should be cleaned up and put back in proper place.
- All steel surfaces should be cleaned with WD-40 and wiped dry or waxed.



SUMMARY OF PORTABLE/HANDTOOL TRAINING REQUIREMENTS

#	Training Requirement	Complete
1	Locate portable power tool machine controls	
2	How to use a keyless chuck drill	
3	Set drill speed and torque on battery drill	
4	How to mount sand disc/belt/paper on sanders	
5	How to crosscut with handheld circular saw	
6	Proper use of hand tools	
7	How to load an air nail gun	
8	How to oil an air nail gun	
9	Discuss clean up	

Track Saw

INTRODUCTION

A track saw (also referred to as a plunge saw) is a type of hand-held circular saw which slides on a guide rail during operation. This allows the operator to perform long and accurate cuts. Track saws, unlike hand-held circular saws, plunge into the material to a pre-determined depth during the cut, increasing operator safety and allowing for reduced splintering and tear-out; the depth-of-cut is not fixed and can be adjusted to be just slightly over the thickness of the board being cut. This property allows a track saw to also cut shallow grooves into the workpiece, if necessary. The track saw system consists of a saw, a track that guides the saw, and in many cases, a vacuum system to eliminate most all of the sawdust from the cut.



Machine Nomenclature

Festool TS60 KEB

Saw Track FS 1400/2

Vacuum System

Watch a short video at the QR code or URL on track saw operations.



URL:

<https://www.youtube.com/watch?v=HnUEIXkSRPM>



<i>Operations</i>	<i>Hazards</i>
Highly accurate cuts	Track shifting
Breaking down sheet goods	Lacerations and amputations of fingers
Mitering edges on plywood	Kickback
	Noise

GENERAL SAFETY GUIDELINES – see General Power Tool Safety Guidelines

MACHINE SPECIFIC GUIDELINES

- **Report any and all problems to the supervisor.**
- Do not overreach. Always keep footing and balance.
- Do not force the tool. Check and see what is causing the problem.
- Always use a backer piece of insulation to keep from damaging the table surfaces. A piece of insulation is in the plywood rack in the back of the shop.
- Do not use track saw with no dust hose connected. Always use a vacuum with dust hose connected.
- Kickback can occur when plunge cutting or no.
- Let the saw get up to speed before engaging wood.

ADVANCED OPERATIONS – see the supervisor.

CLEAN UP:

Sweep up debris.

Put equipment away in cases.



SUMMARY OF TRACK SAW TRAINING REQUIREMENTS

#	Training Requirement	Complete
1	Locate all track saw machine controls	
2	Explain the use of backer foam board to cut on	
3	Set up track saw with shop vacuum for dust collection	
4	Assemble track and check alignment	
5	Disassemble track and store in tool closet	
6	Set and cut work piece	
7	After cut, stop saw, raise and remove from track	
8	Discuss cleanup operations	



Hollow Chisel Mortiser

The hollow chisel mortiser (also called the square chisel mortiser), is like a drill press in many respects. It combines the cutting action of a four-sided chisel with the action of a drill bit in the center. The bit clears out most of the material to be removed, and the chisel ensures the edges are straight and clean.



Machine Nomenclature

Powermatic Model 701 ¾ HP

Operations

Milling mortises for mortise and tenon joints.



Watch a short video at the QR code or URL on hollow chisel mortiser operations.



URL: <https://www.youtube.com/watch?v=xhrEThSCHT8>



Operations	Hazards
Milling mortises for mortise and tenon joinery	Inadvertent starting during setup. Inhalation of dust High force required to plunge chisel into work. Noise

GENERAL SAFETY GUIDELINES – see General Power Tool Safety Guidelines

MACHINE SPECIFIC GUIDELINES

- **Report all problems to the supervisor.**
- Keep your fingers at least 3 inches from the chisel.
- Ensure the mortiser is securely bolted or clamped to the work surface.
- Make sure the work piece is securely attached or clamped to the mortiser table.
- Never use your hand to hold work.
- Do not put your hand or fingers under rotating bit.

ADVANCED OPERATIONS – see the supervisor.

- If auger and chisel are dull see supervisor on how to sharpen.
- If in doubt, ask the supervisor.
- Report all problems to the supervisor.

CLEAN UP:

- Remove auger and chisel from mortise. (If hot from use, let cool.)
- Clean up auger with WD-40 and wipe dry. Do the same with the chisel. Put into container/holder. Put back in proper drawer.
- Knock all chips out of mortise you just made.
- Unclamp and move mortise into storage area. (If not bolted to workbench).
- Blow off mortise and table to floor, then sweep up.



SUMMARY OF MORTISER TRAINING REQUIREMENTS

#	Training Requirement	Complete
1	Locate all hollow chisel mortiser machine controls	
2	Install chisel and auger	
3	Square up chisel to table fence	
	Ensure work piece is securely clamped to mortiser table	
4	Set depth stop	
5	Set hold down clamp	
6	Set table and fence	
7	Cut a mortise	
8	Discuss cleanup	

Domino Mortise and Tenon Jointer

INTRODUCTION

The Domino Mortise and Tenon Jointer is designed to produce mortises in soft and hard wood, chip board, plywood, and fiber boards. It is similar to a biscuit jointer, but with important differences. While a biscuit is loosely considered a spline, a domino is a true floating tenon. The primary distinction is the orientation of the grain, depth of the penetration, and the precise location of the tenon. The wood grain of a biscuit is predominately in-line with the joint. A tenon achieves its strength because the grain of the tenon is perpendicular to the joint. The Domino is also a very portable mortise tool allowing the worker to take the tool to the work, instead of bringing the work to the tool.

The Domino Tenon Jointer is a single use tool. Any applications beyond this are regarded as improper use, may lead to injury or damage to the tool, and should not be attempted.

Machine Nomenclature

Festool DF 500 Q

Vacuum System



Watch a video at the QR code or URL on Festool Domino operations.



URL:
<https://www.youtube.com/watch?v=RRbrcc0ulsw>

Operations	Hazards
Highly accurate mortises	Noise
Portable operation	Contact with fingers and hands

GENERAL SAFETY GUIDELINES – see General Power Tool Safety Guidelines

MACHINE SPECIFIC GUIDELINES

- Secure the workpiece in such a manner that cannot move while being bored.
- **Connect the dust extraction system to the dust port, 2.11, and check system to ensure it is functioning. The Domino cannot be operated without a functioning dust extraction system.**
- Always hold the Domino with both hands at the motor housing, 1.5 and the additional handle on the fence, 1.1.
- **Adjust Mortise Width Dial, 1.2, only when Domino is running.**
- Before turning the Domino on, make sure all adjustment handles are locked and the tool is safe to power on.
- Adapt feed rate to the jointer bit diameter and the material type. Work with a constant feed rate.
- Only lay the Domino down when it has fully stopped.

MACHINE SET UP AND OPERATION FOR MORTISE (edge to edge mating)

- Connect power cable to power inlet, 1.6.
- All dimensions on the Domino are in mm.
- Check cutter for proper size by using the 8mm wrench to pry up on fence body

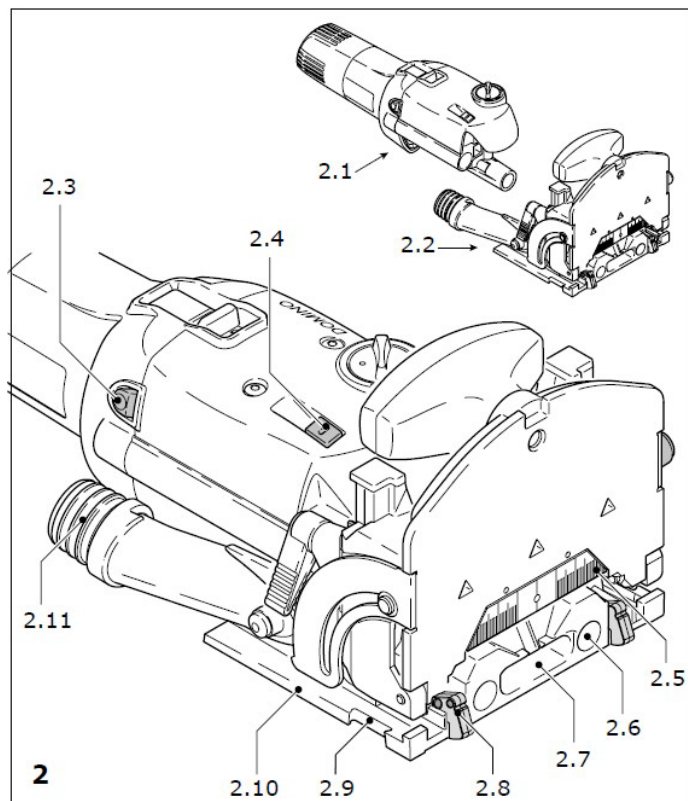
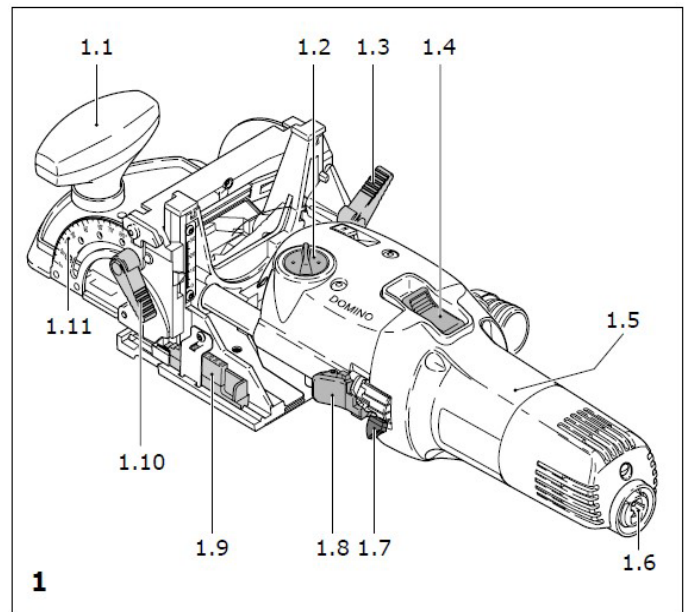



release lever, 2.4. Use shaft lock, 2.3, and the 8mm wrench when removing and reinstalling cutter. Only snug the cutter on shaft. Cutter size must be matched to the domino tenon.

- Connect dust extraction hose to dust port, 2.11.
- Adjust fence height to wood thickness. For $\frac{3}{4}$ stock and a fairly centered domino, set to 20mm on board thickness gauge, 1.9, or 10mm on vertical scale.
- Select domino size. A rule of thumb is domino thickness should be about $\frac{1}{3}$ of the board thickness. For this application select a 6mm thick by 40mm long, or 6x40.
- Adjust the depth of the cut. For this application and half the domino in each board, select 20mm on the depth of cut lever, 1.7, by first pressing the depth lever lock, 1.8, and then moving the depth lever to the 20mm mark.
- Mark boards with a line across the two boards where the center of the domino needs to be.
- Adjust fence miter gauge, 1.11, to 90 degrees.
- Secure board to workbench or table.
- Grip motor body in one hand.
- Slide power switch forward to power on.
- Adjust mortise width dial, 1.2, to shortest width (leftmost position). Only move this dial when the Domino machine is operating.
- Grab the front of Domino machine using the auxiliary handle, 1.1, with free hand.
- Looking behind the auxiliary handle and down at the fence, locate the “zero” gauge line and place the gauge line on the board marking. Hold the Domino at this position securely.
- Plunge the Domino into the wood with a slow steady feed.
- Once bottomed out, back out the Domino machine and repeat the plunge.
- Repeat this operation on other board.

ADVANCED OPERATIONS – see the supervisor.

CLEAN UP

- Blow off exterior of the machine, but don't blow air into the motor vents.
- Blow out impacted sawdust from the mortising cutter area.
- With exterior dust free, remove fence body and clean and lubricate slides.



SUMMARY OF DOMINO MORTISE TRAINING REQUIREMENTS

#	Training Requirement	Complete
1	Locate all Domino mortise machine controls	
2	Set up dust collection with shop vac	
3	Select the proper size domino	
4	Change mortiser cutter	
5	Adjust fence	
6	Set mortise depth	
7	Machine a mortise	
8	Discuss cleanup	



APPENDIX

1. Alabama Woodworkers Guild AWG-1 Policy

Title: Use of the Woodworking Education Center

Policy No. AWG-1

Date Adopted: 03/01/2010

Revised: 03/02/2022

Statement of Policy:

Use of the Alabama Woodworkers Guild (the “Guild”) Woodworking Education Center (the “WEC”) shall be governed by the requirements as set forth herein.

Reason for Policy:

This Policy sets forth the operating requirements necessary for the safe, efficient and orderly operation of the WEC maintained by the “Guild” for the use of its members.

Policy Requirements:

- A WEC Manager (appointed by the board) shall establish and administer WEC rules and regulations that are necessary to implement the requirements of this policy and/or are necessary for the safe, efficient and orderly operation of the WEC.
- **Members are responsible for their own safety** and must make themselves aware of and comply with all WEC rules and regulations. Woodworking is a dangerous activity. Accidents often occur. A member must not attempt any operation in the WEC for which he/she is unsure of how to accomplish safely, nor shall he/she operate any machine for which he/she is not certain of how to safely operate it. He/she shall



inspect each machine prior to use to assure that it is in safe operating condition.

- All persons in the WEC during hours of operation must have signed a Liability Release Waiver and said Waiver must be on file at the shop.
- Use of the WEC shall be limited to (a) Guild sponsored group work sessions, (b) Guild sponsored training sessions and (c) individual member work sessions.
- The WEC will be open during regular scheduled times provided a shop supervisor is present with the exception of Master Classes in session. When Guild sponsored work or training sessions are scheduled, the work lead or instructor may require the shop be closed to member work sessions.
- Guild sponsored work or training sessions shall have scheduling priority over member work sessions and priority over the use of equipment.
- Hours of operation shall be set by the WEC Manager or his designee.
- Work sessions shall be scheduled by the WEC Manager or his designee.
- Use of the WEC is limited to Guild members only. Members may be accompanied by “helpers” to assist with material handling, glue ups, etc. Any person under 18 years of age must be accompanied and supervised by a parent or guardian.
- Individual members will not use the WEC for monetary gain or for commercial purposes.
- A designated Shop Supervisor must be on the premises at all times that any work session is in process.
- The Shop Supervisor(s) may set a maximum number of people using the WEC at any one time as may be warranted by nature of on-going activities.



- The Shop Supervisor shall require any member, who in his opinion is performing an unsafe act, to stop. The member must stop the act; however, he/she may appeal the decision to the WEC Manager.
- Members will be required to use their own tools and equipment where not supplied by the Guild.
- Members will provide whatever materials and supplies that may be required for their personal projects and will replace any Guild supplies they may use.
- Members are responsible to maintain a clean working environment at all times.
- Members will clean-up their work areas before leaving the WEC.
- The WEC Manager may suspend or revoke any member's WEC usage privileges for failure to comply with WEC rules. A member may appeal such a suspension or revocation to the board.
- The requirements of this Policy shall be prominently posted and displayed on the WEC premises.
- Consumption of alcoholic beverages of any kind is strictly prohibited on the WEC premises.